



# Installation instructions, accessories

Volvo Car Corporation Gothenburg, Sweden

Instruction No	Version	Part. No.
30721137	1.3	31414735, 30790158, 30790156

## Sill molding, illuminated

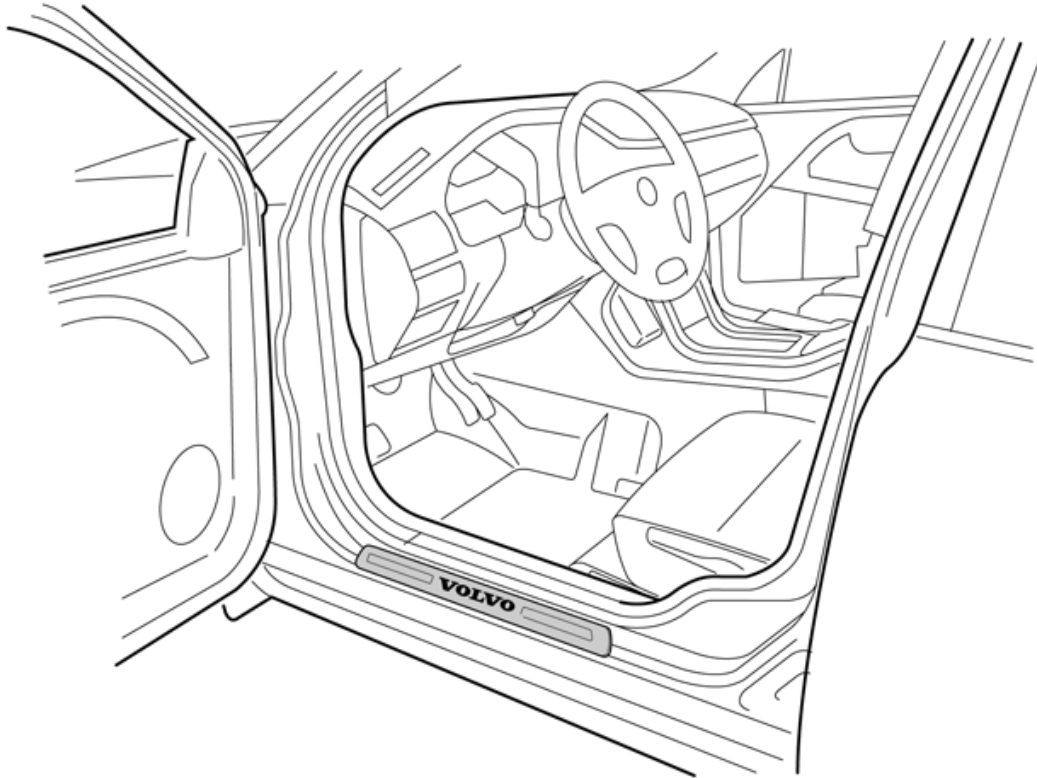

IMG-266944



# Installation instructions, accessories

Volvo Car Corporation Gothenburg, Sweden

## Equipment



IMG-239681



IMG-239660

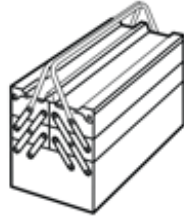

A0000162



M0000276

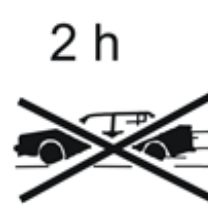

A0000177



A0000214

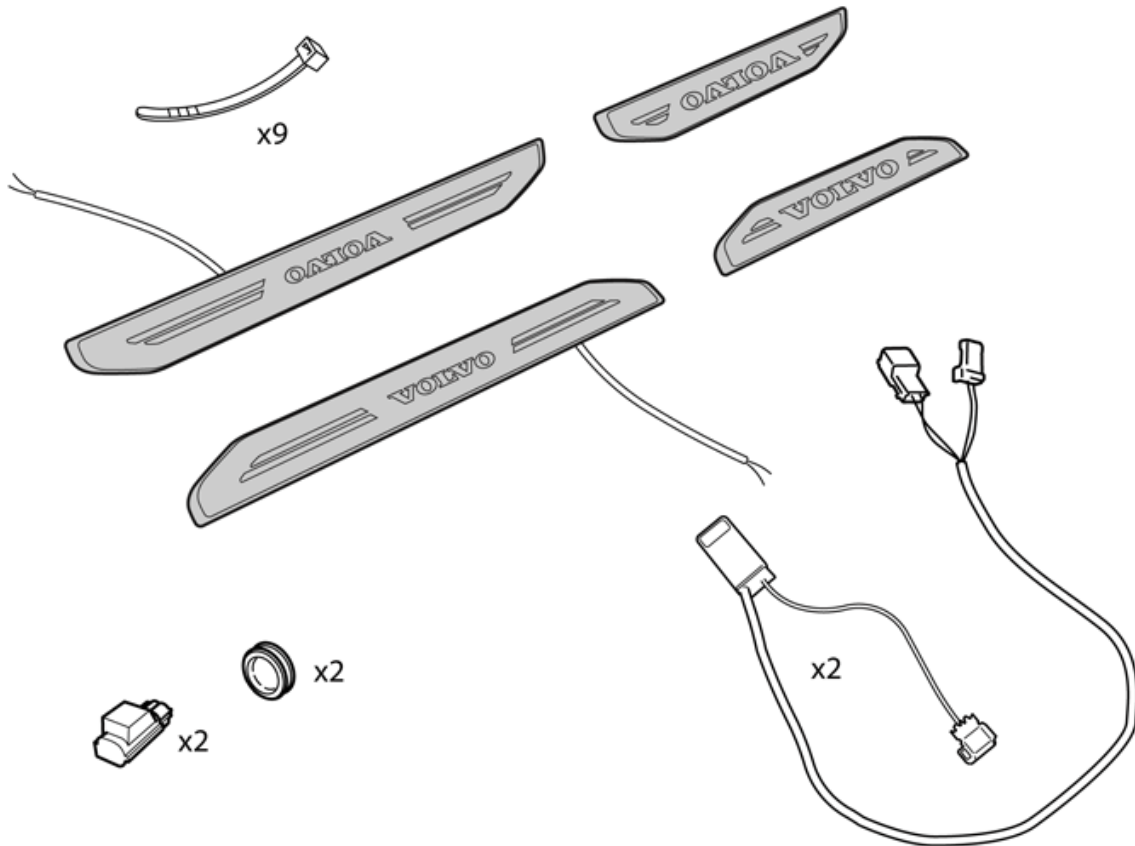

IMG-297963



# Installation instructions, accessories

Volvo Car Corporation Gothenburg, Sweden

Any comments on this publication? Please contact your nearest retailer. Thank You!

Publ.no:	Issue:	Kit no:
Comments:.....		
.....		
.....		
.....		

From:	
Address:	
Telephone:	
Telefax:	

IMG-213320



# Installation instructions, accessories

Volvo Car Corporation Gothenburg, Sweden

## INTRODUCTION

Read through all of the instructions before starting installation.

Notifications and warning texts are for your safety and to minimise the risk of something breaking during installation.

Ensure that all tools stated in the instructions are available before starting installation.

Certain steps in the instructions are only presented in the form of images. Explanatory text is also given for more complicated steps.

In the event of any problems with the instructions or the accessory, contact your local Volvo dealer.

### Note!

The work is done the same on left-hand drive and right-hand drive cars (mirrored). Left-hand drive car is shown.

## Sill mouldings front doors

### Sill mouldings front doors

Turn the ignition key to position 0.

Disconnect the battery negative lead.

### Note!

Wait at least three minutes before unplugging the connectors or removing other electrical equipment.

1

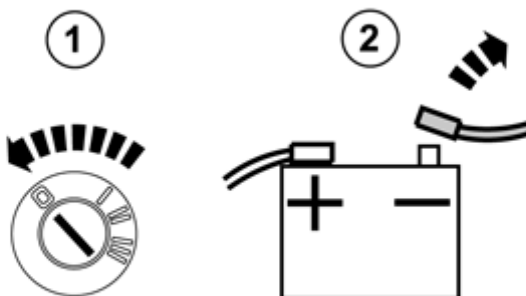

IMG-246024



# Installation instructions, accessories

Volvo Car Corporation Gothenburg, Sweden

2

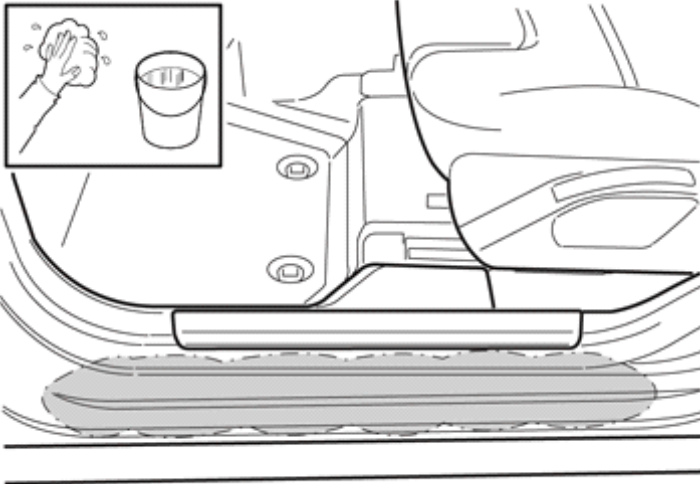

Wash the door sill

IMG-297967

3

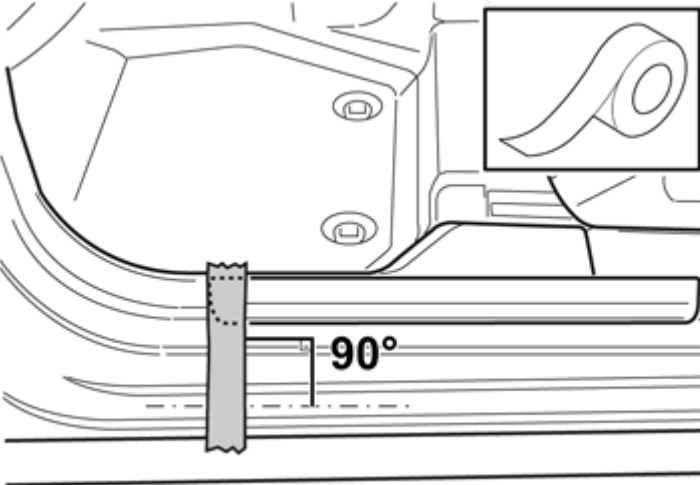

Place a strip of tape in the front edge of the sill panel, square to the edge of the door sill.

IMG-297968

4

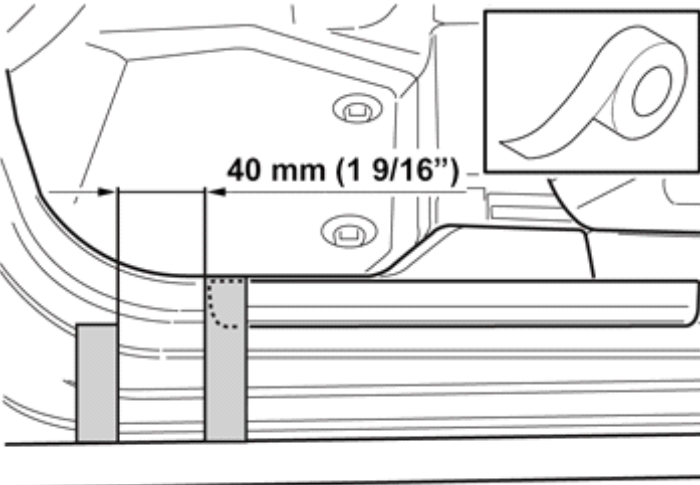

Measure out a distance of 40 mm (1 9/16") from the front of the tape strip and forward, to mark the sill moulding's front position. Fasten a tape strip as shown.

IMG-323263



# Installation instructions, accessories

Volvo Car Corporation Gothenburg, Sweden

5

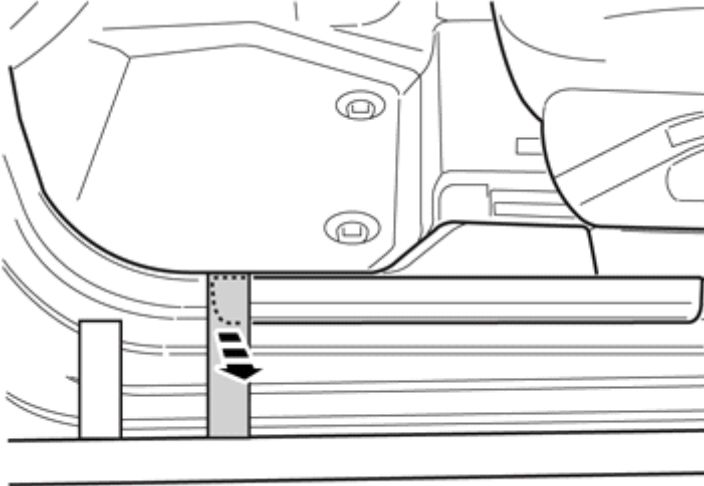

Remove the rear strip of tape.

IMG-323264

6

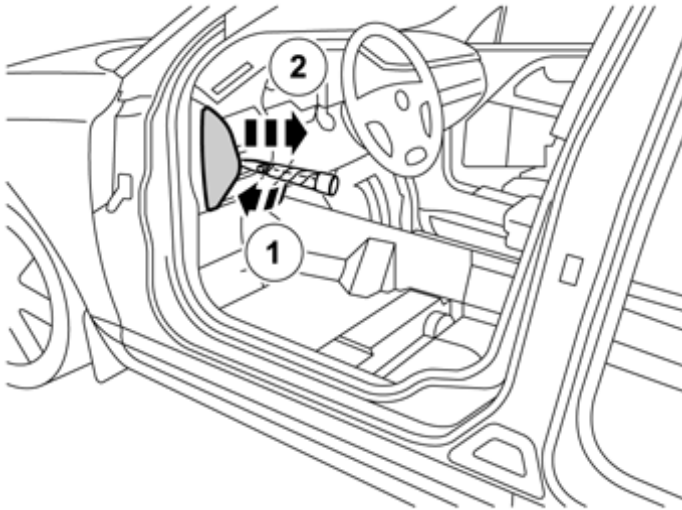

Remove the end of the dashboard by first carefully prying it (1) with a weatherstrip tool until the two catches release, then it off backwards (2)

IMG-297971

7

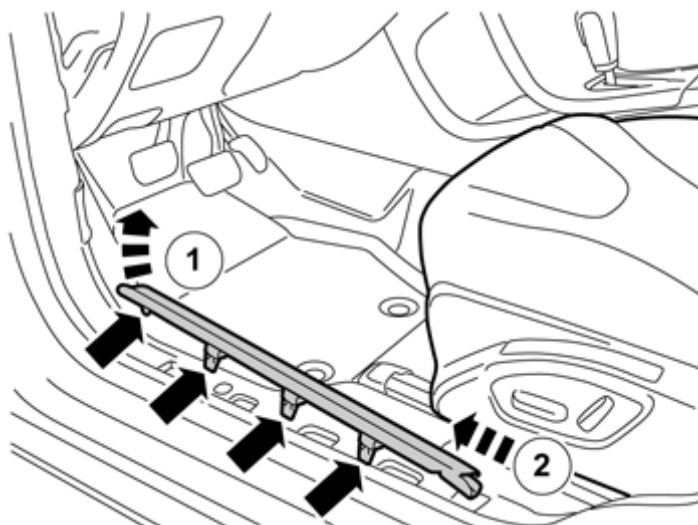

Remove the rear sill panel in the front door by first prying loose the clips starting at the front and working back.

Unhook the panel at the rear edge.

IMG-297972



# Installation instructions, accessories

Volvo Car Corporation Gothenburg, Sweden

8

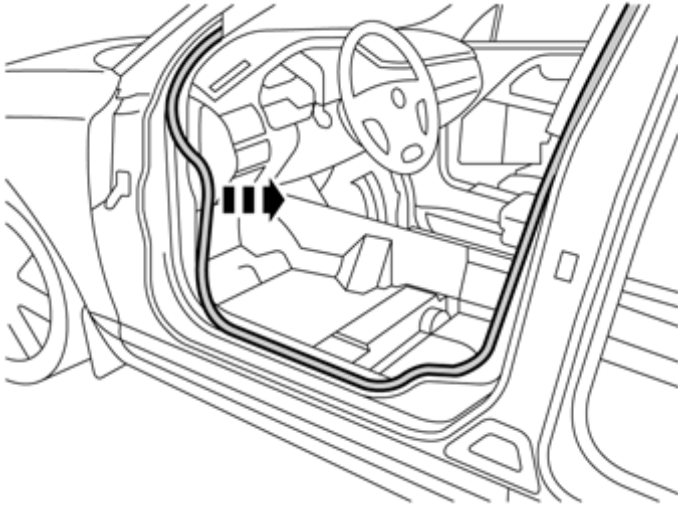

Detach the rubber moulding on the front edge of the door opening.

IMG-255725

9

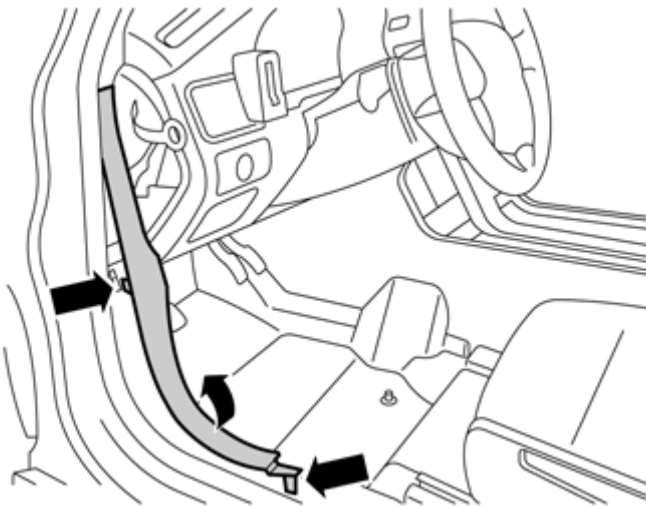

Remove the lower A-pillar panel in the front door by first lifting it up at the rear edge. Pull it back until the clip on the centre releases. Then pull it away diagonally down from the A-pillar panel.

IMG-255726



# Installation instructions, accessories

Volvo Car Corporation Gothenburg, Sweden

10

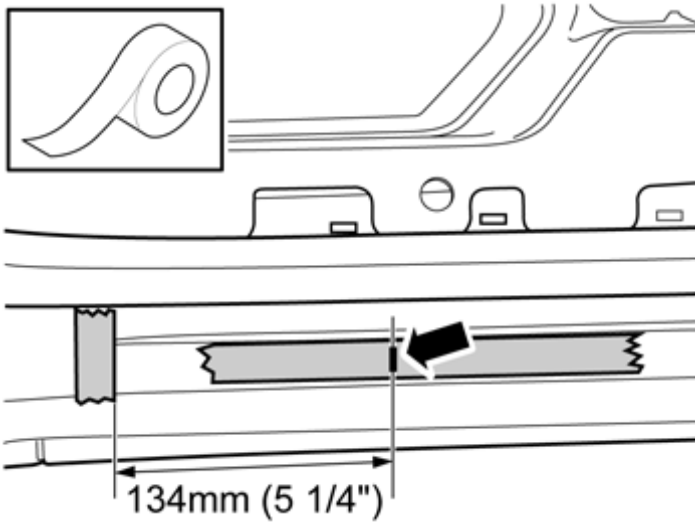

IMG-297973

Fasten a tape strip on the outer part of the sill, butt with the longitudinal embossing.

Measure out 134 mm (5 1/4") from the position where the moulding's front edge should be and mark on the tape strip.

11

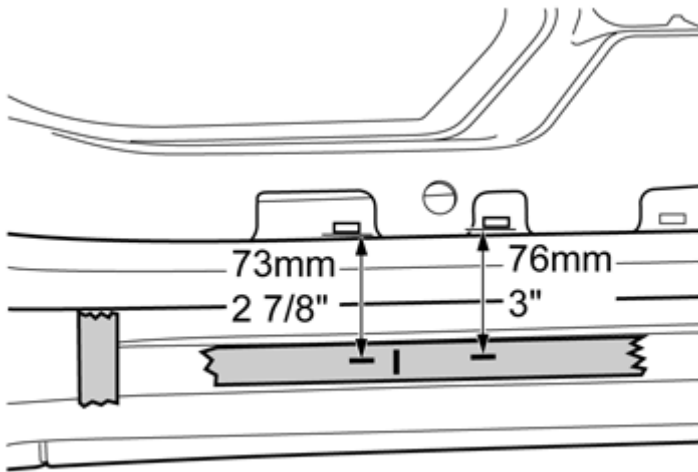

IMG-297975

Measure out and mark measurements 73 mm (2 7/8") and 76 mm (3") on the tape strip from the outer edges on both front clip holes in the sill with a sliding gauge.

12

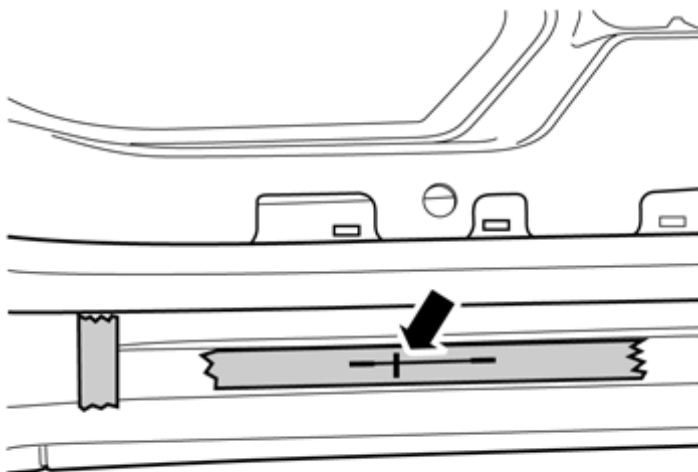

IMG-298003

Now join both markings.





# Installation instructions, accessories

Volvo Car Corporation Gothenburg, Sweden

13

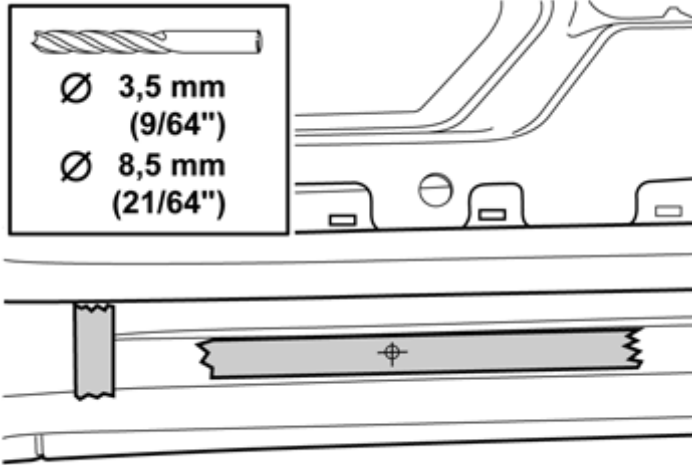

Make a light punch mark and pre-drill the hole in the sill with a  $\varnothing$  3.5 mm (9/64") drill bit.

Drill out the hole using a  $\varnothing$  8.5 mm (21/64") drill bit.

Remove the tape by the hole, but leave the front one in place.

Deburr the edge of the hole, rustproof, and let it dry.

IMG-298123

14

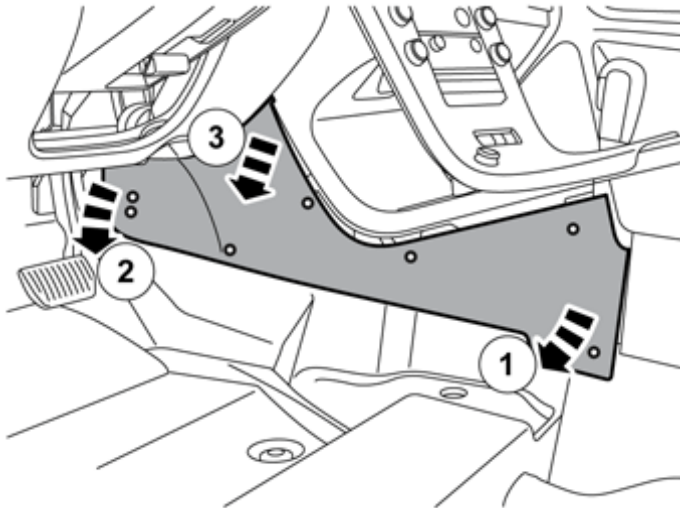

Remove the tunnel console's panel. It is fastened with seven clips on the inside.

IMG-298585

15

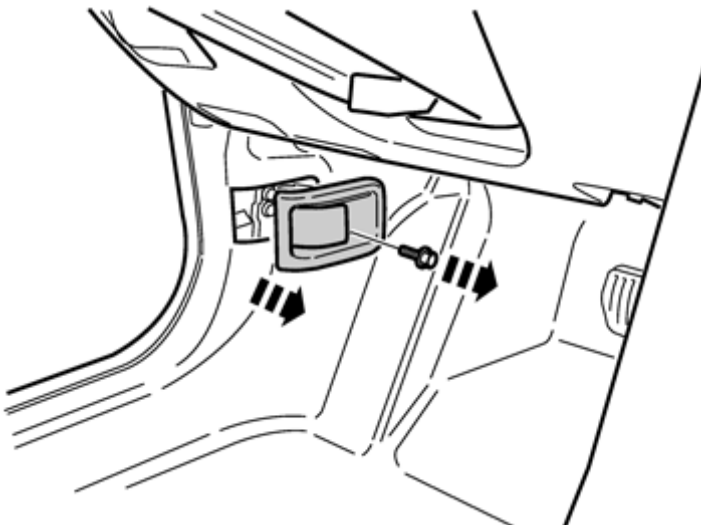

Remove the screw for the bonnet release and pull it out.

IMG-266993



# Installation instructions, accessories

Volvo Car Corporation Gothenburg, Sweden

16

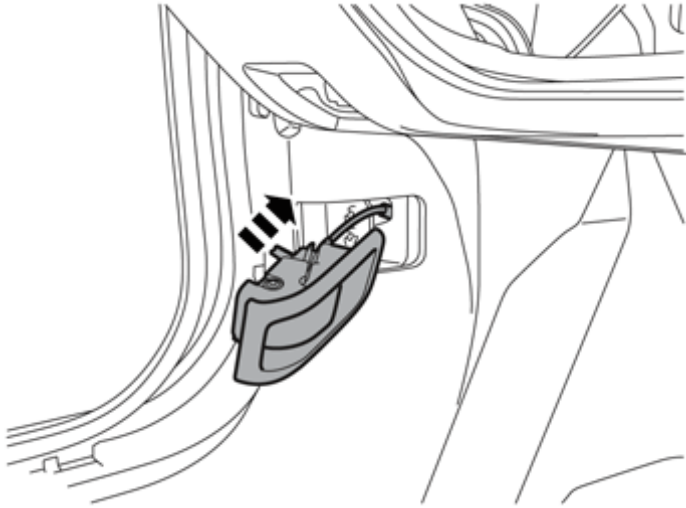

IMG-298163

Move the opener through the hole in the mat.

17

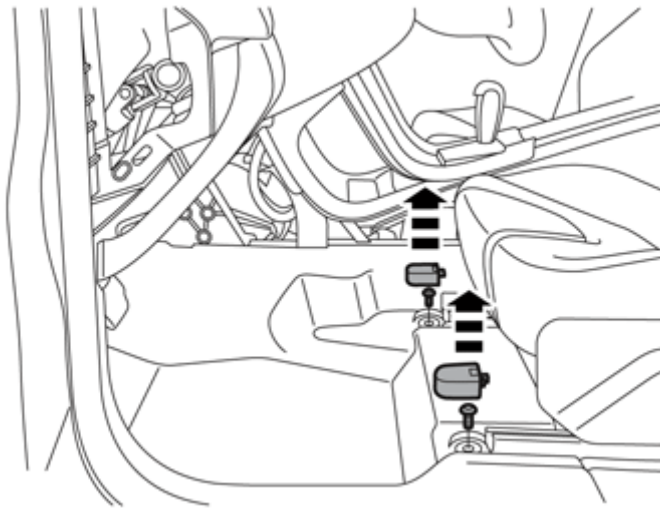

IMG-298164

Bend off the covers over the seat's attachments and remove the screws.



# Installation instructions, accessories

Volvo Car Corporation Gothenburg, Sweden

18

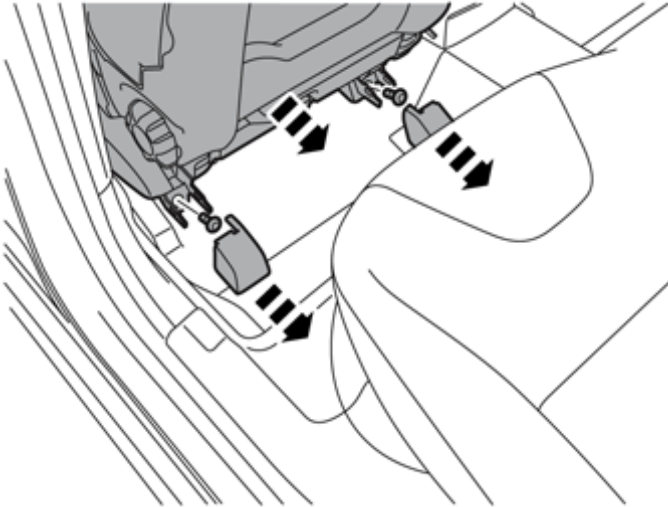

IMG-298165

Carefully bend off the covers in the driver seat's rear attachments with a weatherstrip tool.

Remove the screws.

Move back the seat slightly to expose the front floor mat at the trailing edge.

19

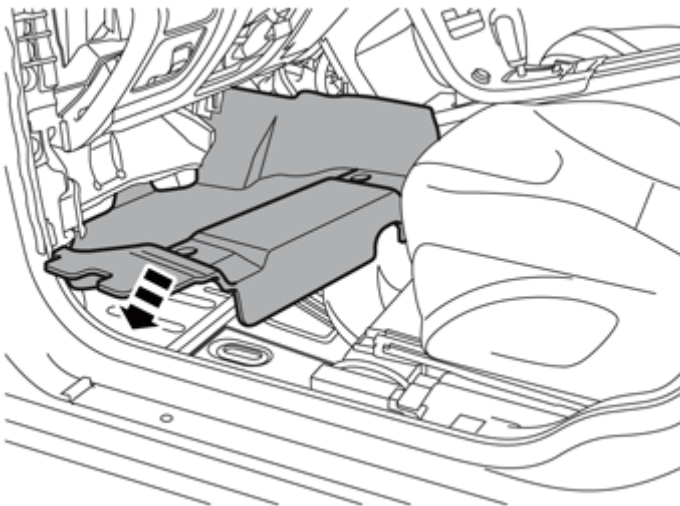

IMG-298166

Lift the seat at the leading edge and pull away the mat.

Lift out the mat.

20

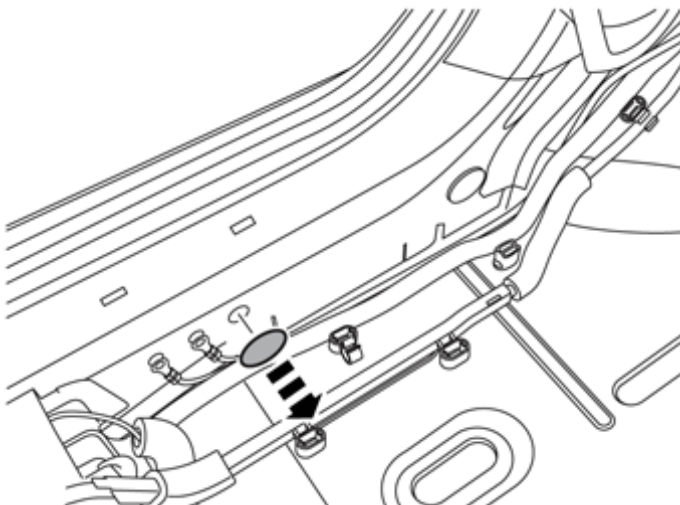

IMG-298167

Remove the blank seal washer on the inside of the door sill.

Continue with previous steps 2-4 on the car's other side during the time that the rustproofing dries.



# Installation instructions, accessories

Volvo Car Corporation Gothenburg, Sweden

21A

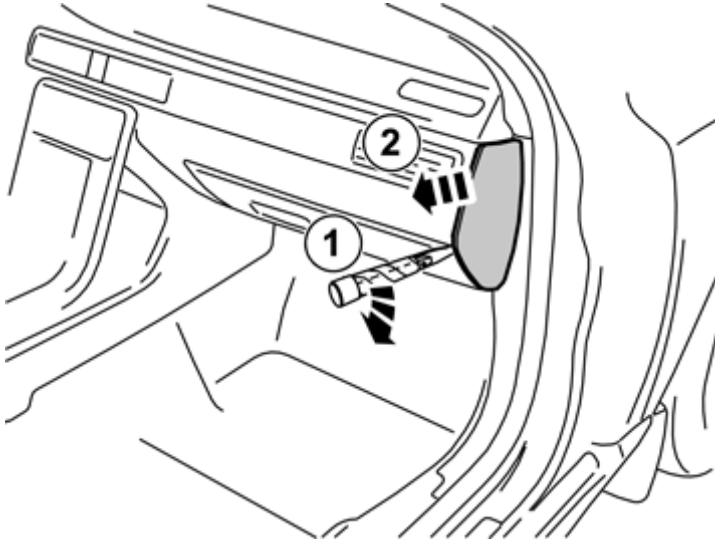

IMG-222265

**A**

Remove the dashboard's end panel on the right side by carefully twisting it (1) using a weatherstrip tool until the two catches release and then pull it backwards (2).

**B**

If the car has a passenger airbag, unplug the connector for the switch.

21B

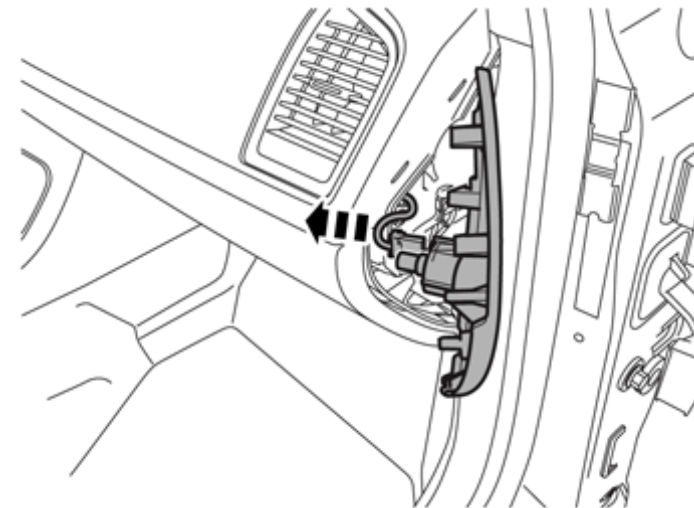

IMG-298168

Remove the sill panel in the front door by first carefully prying it off at the front edge, then pull it up until the three clips release. Then, pull it away forwards at an angle.

22

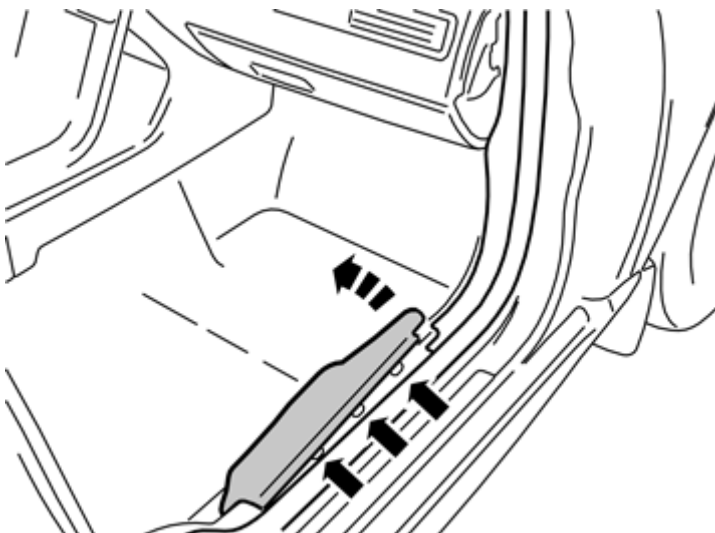

IMG-231432



# Installation instructions, accessories

Volvo Car Corporation Gothenburg, Sweden

23

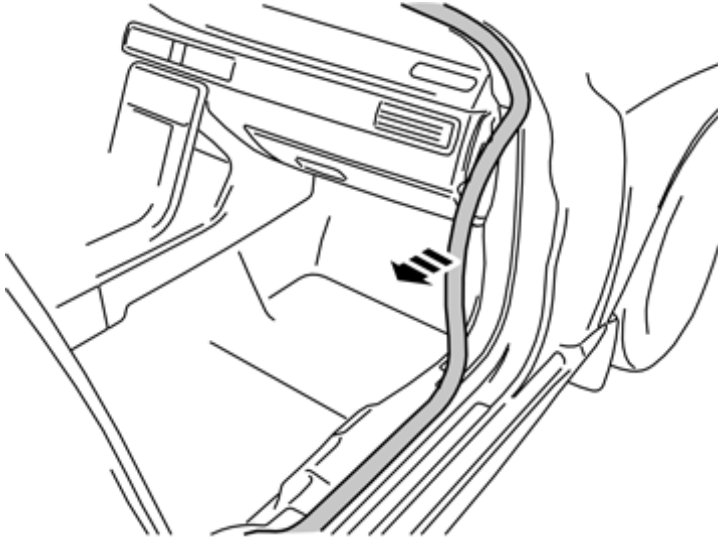

IMG-222267

Remove the rubber strip in the front edge of the door opening by the lower A-pillar panel on the right side.

24

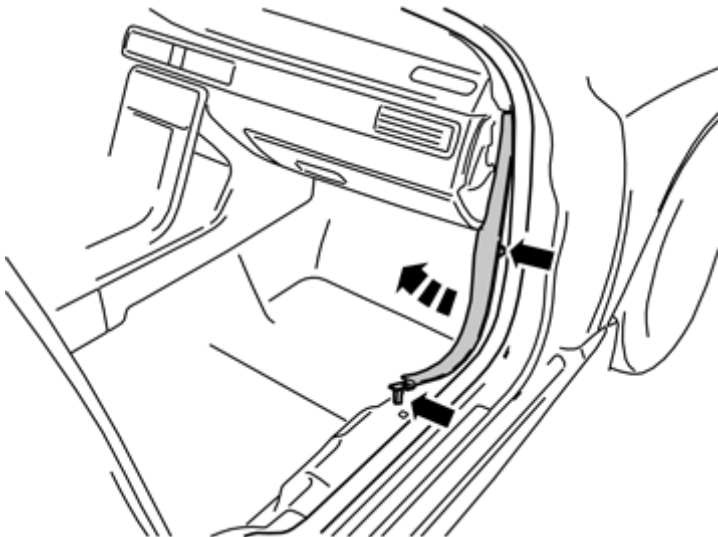

IMG-231433

Remove the lower A-pillar panel by the right front door by first pulling it up at the rear edge until the clip there releases. Then pull it back further until the clip on the centre releases. Then pull it away diagonally down from the upper A-pillar panel.

Continue with previous steps 10-13.

25

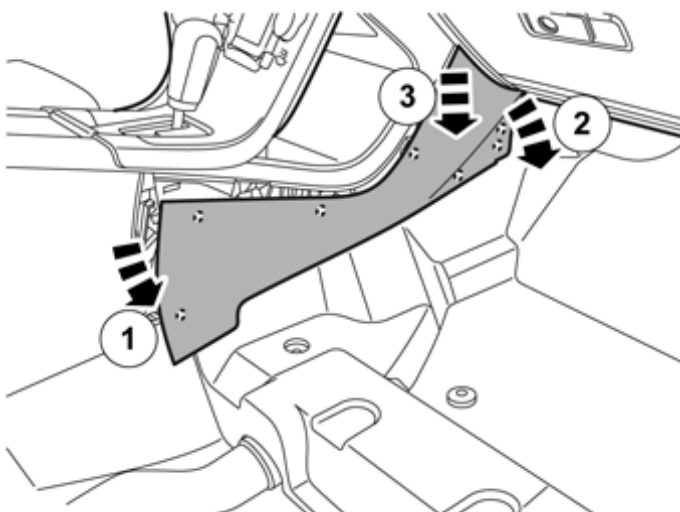

IMG-303343

Remove the tunnel console's right side panel by carefully pulling it away starting at the front edge. The side panel is fastened with seven clips on the inside.





# Installation instructions, accessories

Volvo Car Corporation Gothenburg, Sweden

26A

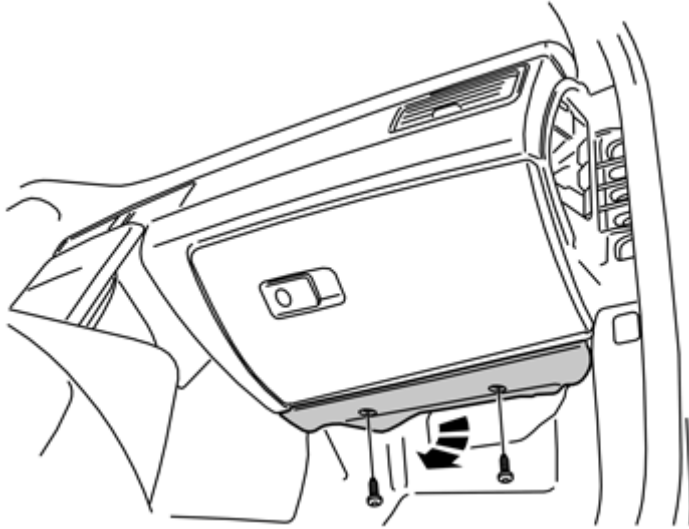

IMG-222268

**A**

Remove the bolts of the panel underneath the glovebox and remove it.

**B**

Unplug the lighting connector and move the panel aside.

26B

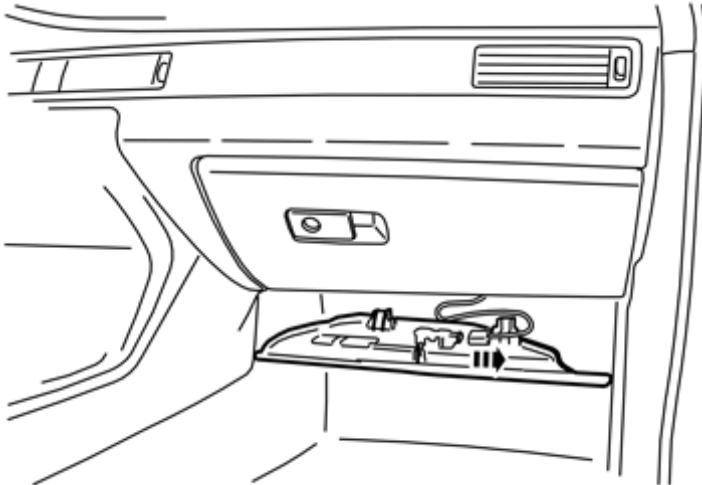

IMG-222270

27

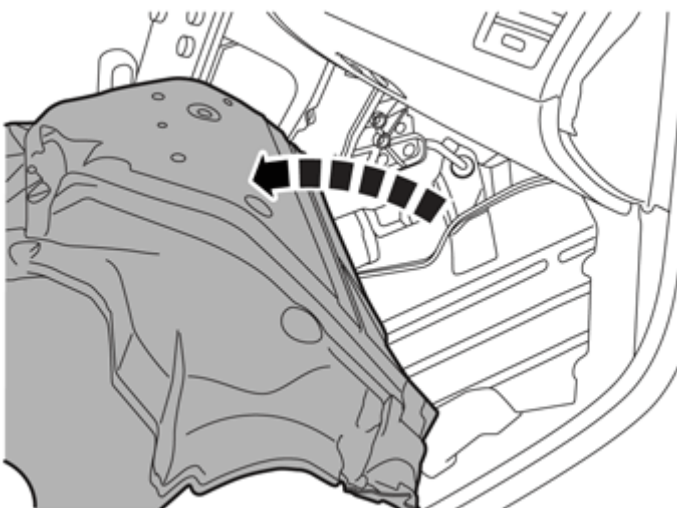

IMG-298169

Fold back the floor mat so that the floor is exposed.



# Installation instructions, accessories

Volvo Car Corporation Gothenburg, Sweden

28

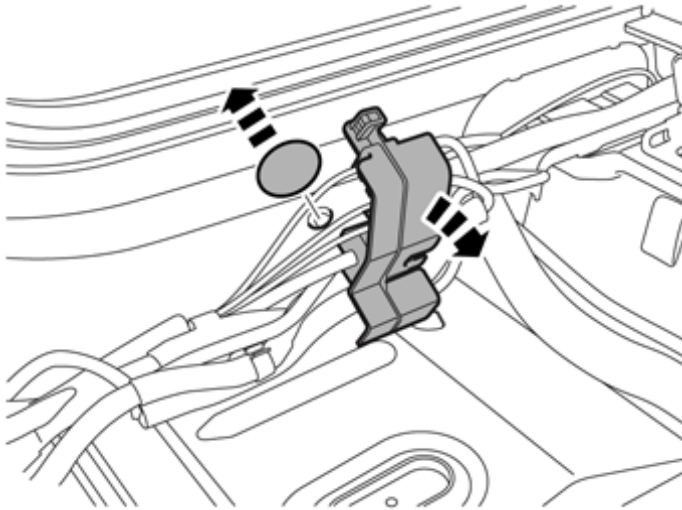

IMG-298183

Loosen the contact bridge on the right door sill's inside and move aside.

Remove the blank seal washer on the inside of the door sill.

**Note!**

Same on left-hand drive and right-hand drive cars.

29

Bend a thin welding rod approx. 150 mm (5 7/8") long.



IMG-298203

30A

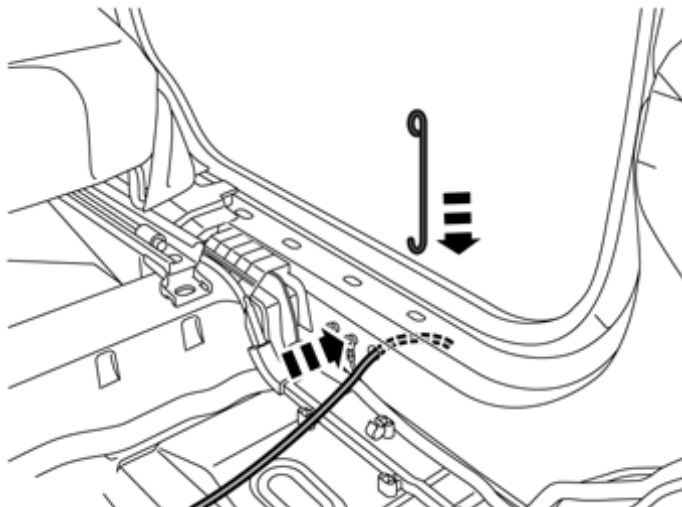

IMG-298204

Get a piece of thicker electrical wire and insert into the hole in the left door sill where the cover washer was installed, through the hole in the middle plate in the bottom sill and out to the outer panel.

**Note!**

Carry out on both sides of the car.

Get the hook and insert down in the drilled hole and carefully pull up the wire. Do not rub off the rustproofing on the edge of the hole.



# Installation instructions, accessories

Volvo Car Corporation Gothenburg, Sweden

30B

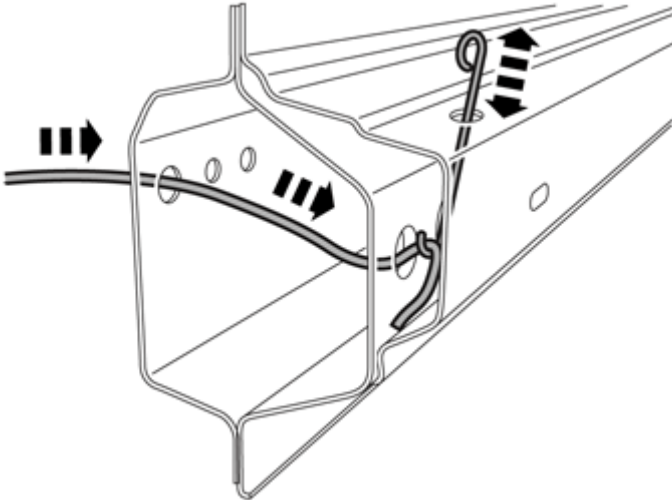

IMG-298205

31

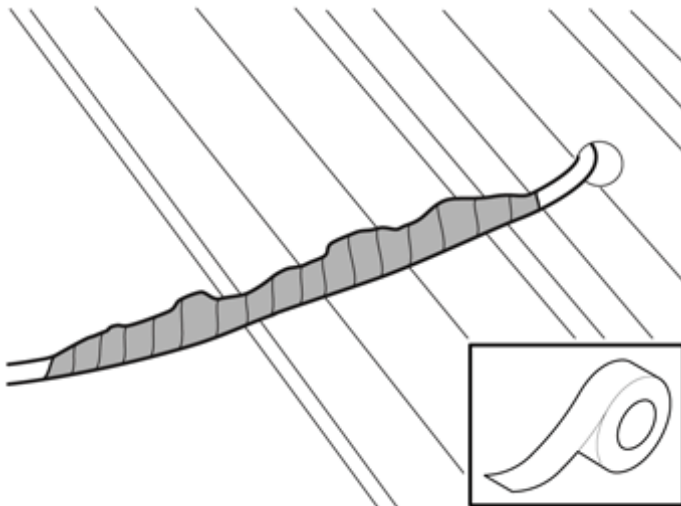

IMG-298206

Get a sill moulding from the kit, tape both wire ends to the casing and the wire for the lead-through.

32

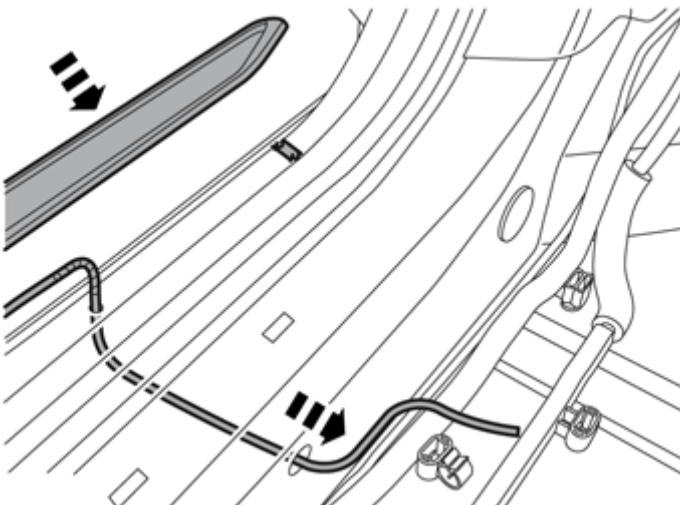

IMG-298207

Now carefully route the wire through the passenger compartment.





# Installation instructions, accessories

Volvo Car Corporation Gothenburg, Sweden

33

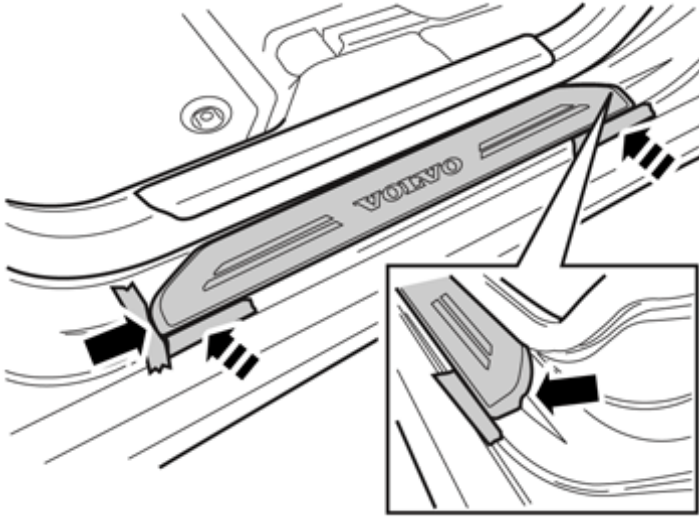

IMG-290343

Position the sill moulding by the strip of tape at the front edge and position it so that the cut-outs in both ends align with the corresponding door sill. Be careful when positioning so that the moulding is not misaligned.

34

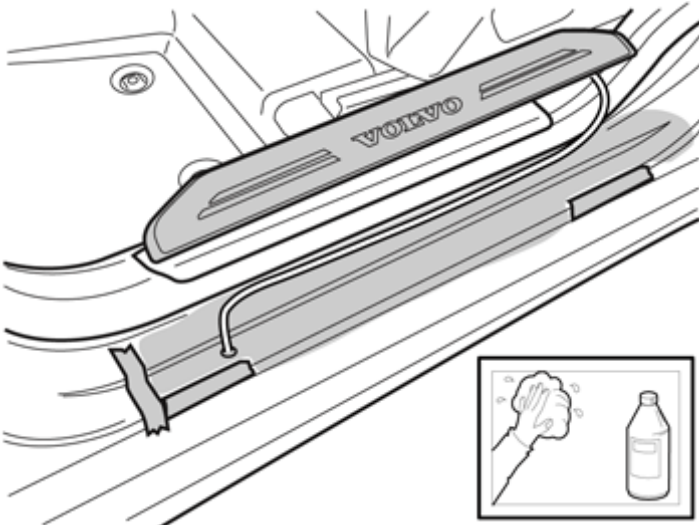

IMG-298364

Clean the marked surface on the sill using isopropanol and wipe dry.

**Note!**

Avoid damaging the rustproofing in the hole's edge.

35

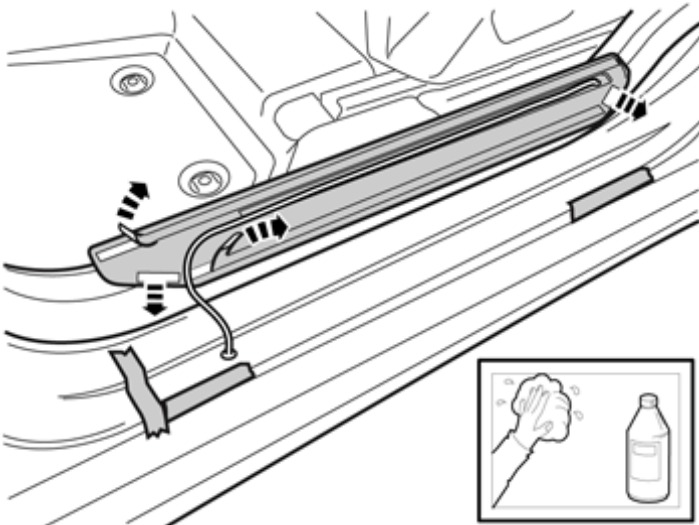

IMG-298363

Fold out the ends at the front edge on the two long fastening tapes.

Remove the protective tape on the two short.



# Installation instructions, accessories

Volvo Car Corporation Gothenburg, Sweden

36

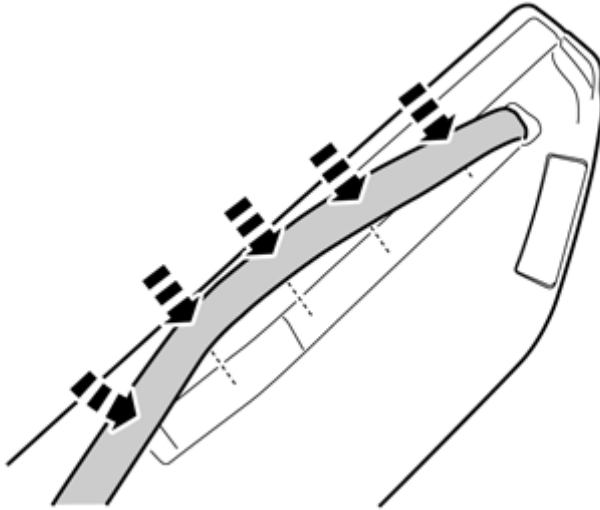

IMG-298365

Pull up the wire's casing as far as possible against the connection in the moulding and press onto the self-adhesive surface.

37

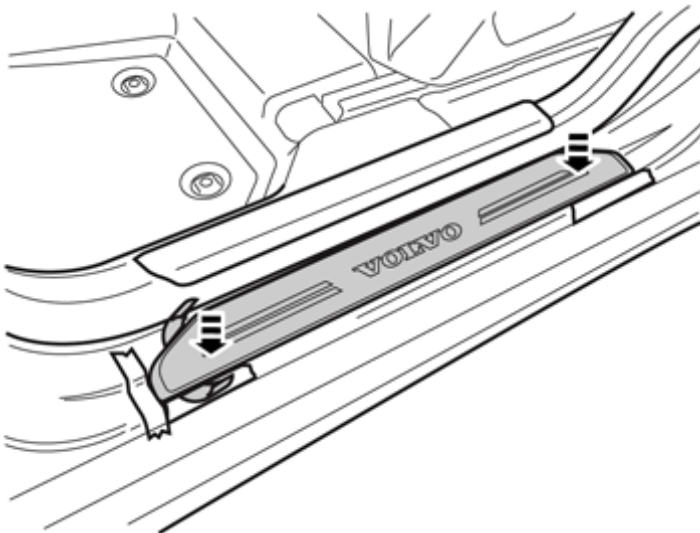

IMG-290346

Position the sill moulding by the tape strip at the front edge and the two by the sides. Do not press the ends into place yet.

Be careful with positioning so that the moulding is not misaligned.



# Installation instructions, accessories

Volvo Car Corporation Gothenburg, Sweden

38

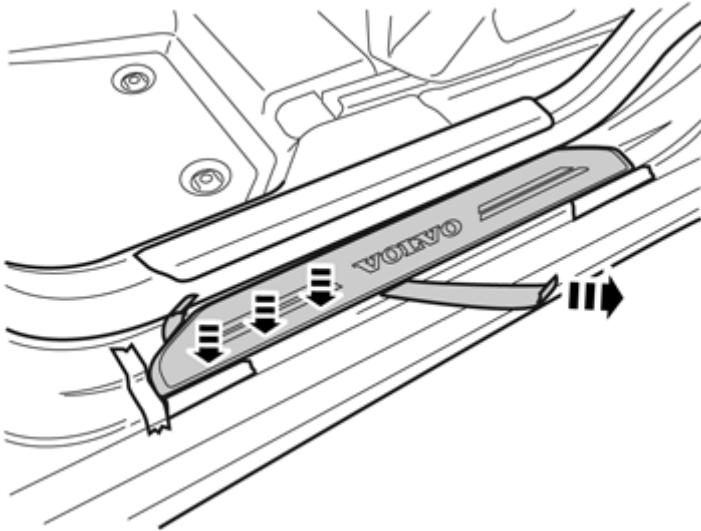

IMG-290347

Carefully pull away the protective tape and successively push down into place, first the outer, then the inner tape. Make sure that the rubber moulding is not in the way.

### Note!

Do not push down the strip too close to the protective tape on the inner tape. Then the strip is almost up against the sill and can catch, causing the tape to break.

39

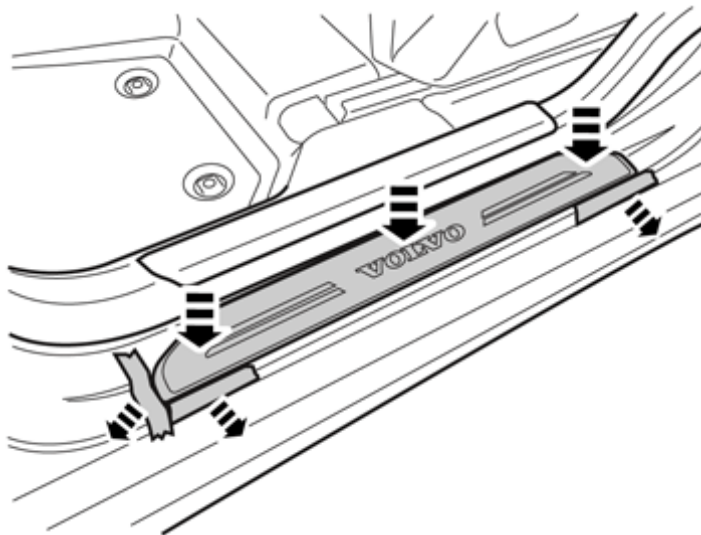

IMG-290348

Press the trim strip down firmly with a pressure of approximately 2 kg/cm<sup>2</sup> along its entire length.

Remove the tape markings.

40

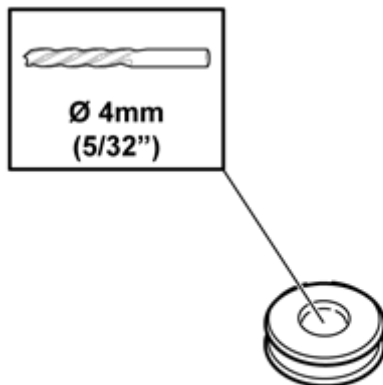

Take the rubber plugs from the kit and drill a Ø 4mm (5/32") hole in the middle on them.

IMG-298369



# Installation instructions, accessories

Volvo Car Corporation Gothenburg, Sweden

41

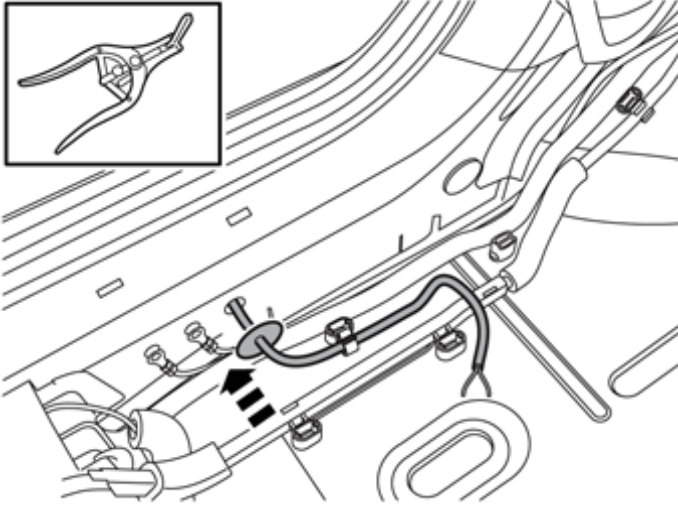

IMG-298370

Get a rubber bushing from the kit, fit it on the wire and fasten in the sill's inside.

42



IMG-298371

Clean the marked surface in front of the thicker of the air ducts with isopropanol and wipe dry.

43

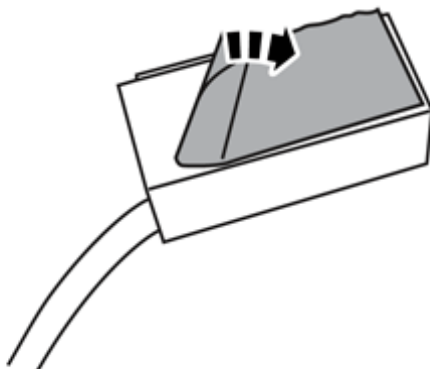

Get a transformer from the kit and remove the protective tape.

IMG-298372



# Installation instructions, accessories

Volvo Car Corporation Gothenburg, Sweden

44

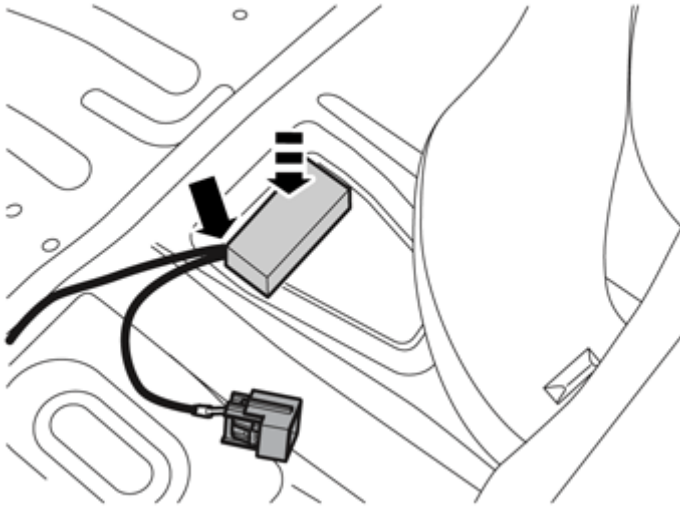

IMG-317165

Secure the transformer as far to the left and as high up in the recess in the floor as possible.

45A

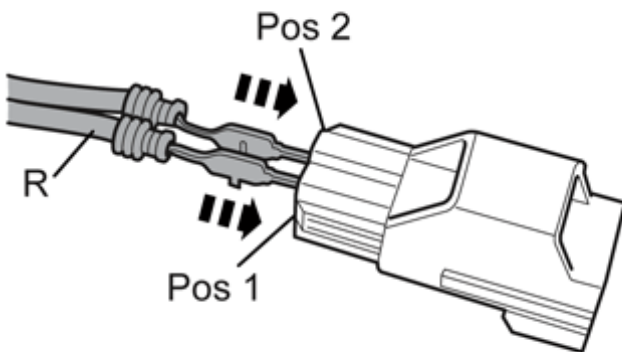

IMG-298374

**A**

Get a loose connector from the kit and press in the cable terminals on the two wire ends on the sill moulding, wire with red (R) marking in position 1, the other in position 2, until a click is heard.

**B**

Press on the white lock inside the connector.

45B

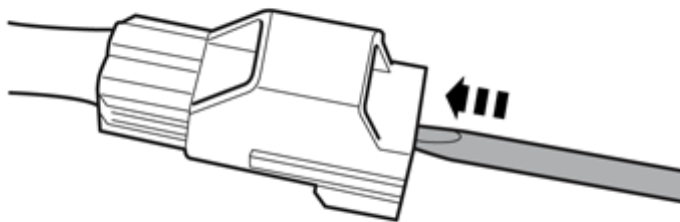

IMG-298375



# Installation instructions, accessories

Volvo Car Corporation Gothenburg, Sweden

46

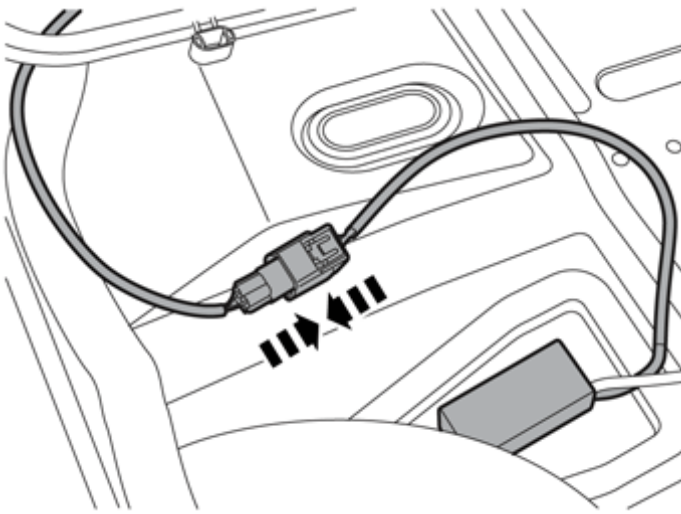

IMG-298483

Route the wire under the holder for the washer fluid hose and connect to the wire from the transformer.

**Note!**

Same on left-hand drive and right-hand drive cars

47

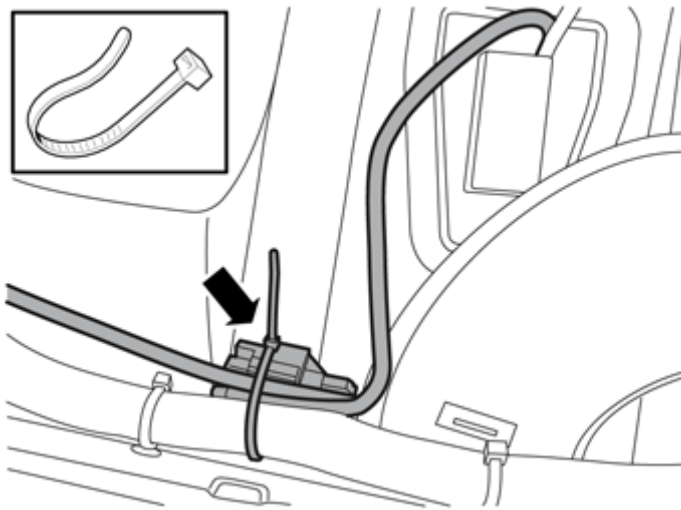

IMG-298484

Clamp down the connector and wires to the existing cable harness.

**Note!**

Same on left-hand drive and right-hand drive cars.





# Installation instructions, accessories

Volvo Car Corporation Gothenburg, Sweden

48

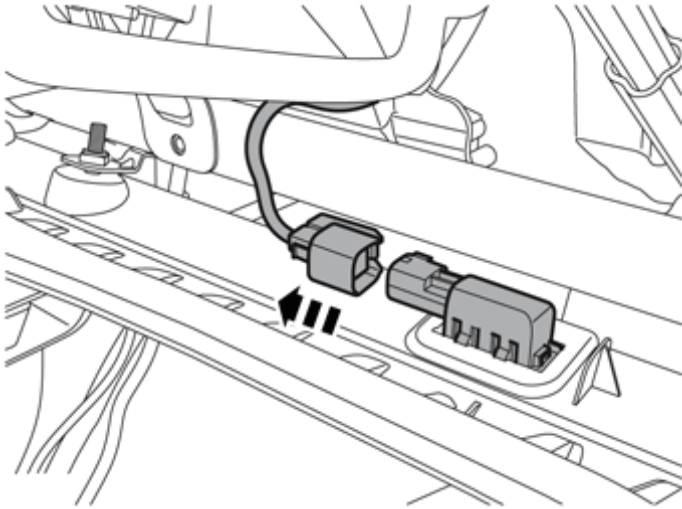

IMG-298485

Unplug the connector for the courtesy lighting under the collision pipe.

49

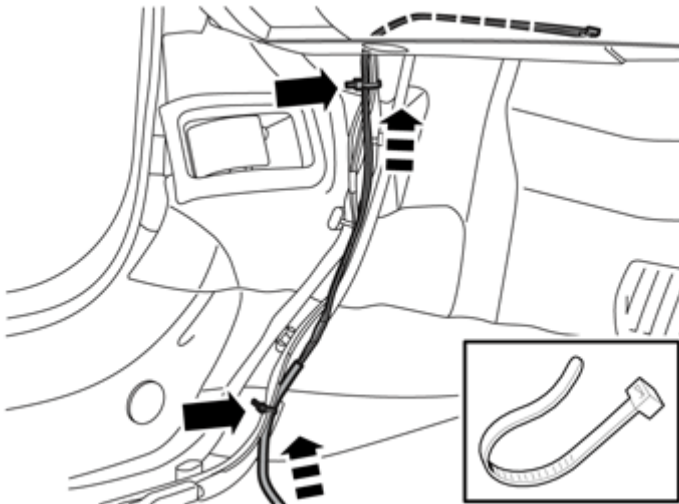

IMG-298486

Pull up the cable harness from the transformer along the existing wires up under the dashboard, along the collision pipe and on to the lighting under the dashboard.

Secure the cable harness at the thin cable harness using cable ties from the kit, however, do not tighten them yet, adjust the length up to the lighting in the panel.

**Note!**

Do not clamp the washer hose, and ensure that the cable harness is clamped so that it does not chafe against sharp edges under the dashboard.

50

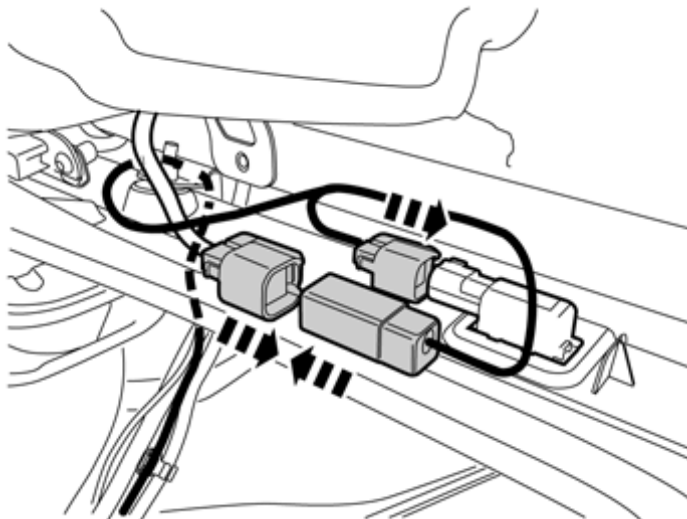

IMG-317166

Connect the prewired cable harnesses female connector to the courtesy lighting.

Connect the two remaining connectors to each other.

Now adjust the cable length up to the transformer and tighten the two cable ties.



# Installation instructions, accessories

Volvo Car Corporation Gothenburg, Sweden

51

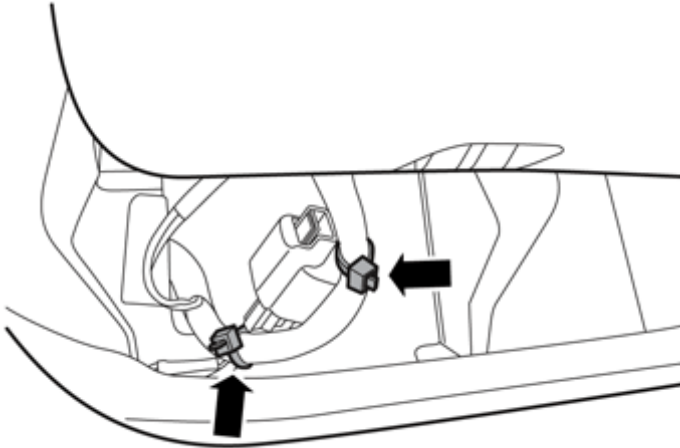

Clamp down loose connectors to existing cable harness under the steering column with cable ties from the kit.

Clamp down the connectors at each end of the cable harness so that they do not rattle.

IMG-298489

52

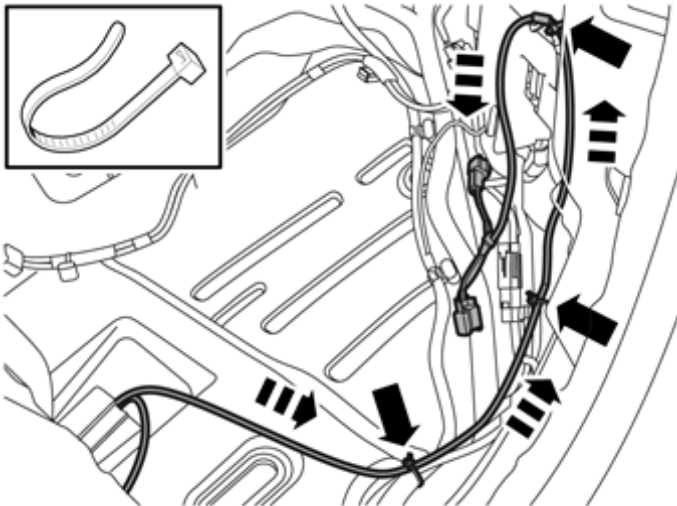

Install the transformer on the right side and plug in connector according to steps 42-47.

Route the long adapter wire to the door sill with existing cable harnesses.

Pull up the adapter wire along the cable harnesses up to upper edge of the contact bridge.

Clamp down to cable harnesses with cable ties from the kit.

IMG-298503

53

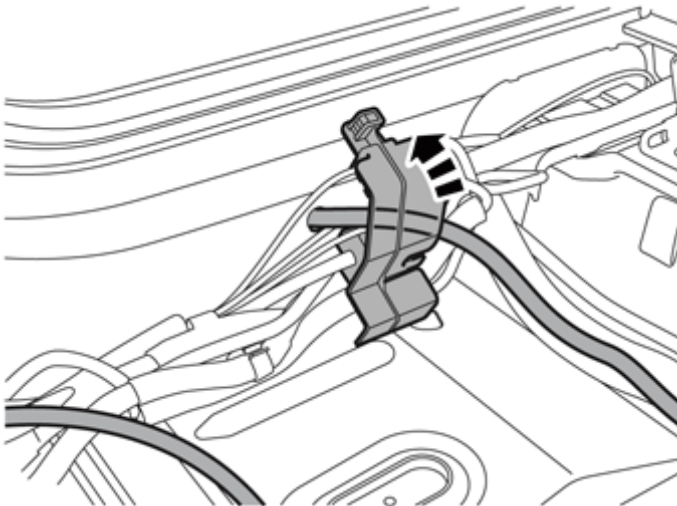

IMG-298523





# Installation instructions, accessories

Volvo Car Corporation Gothenburg, Sweden

54

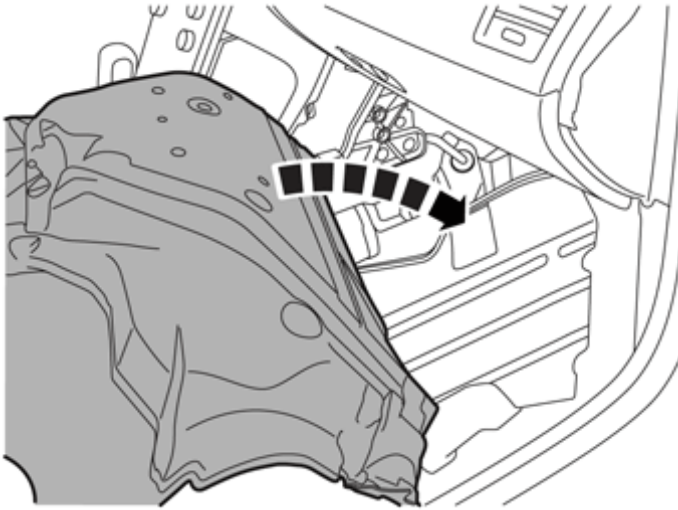

IMG-298524

55A

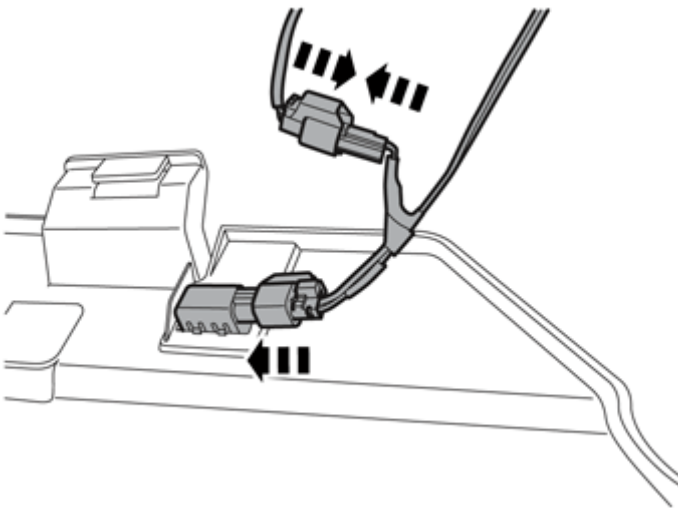

IMG-298525

55B

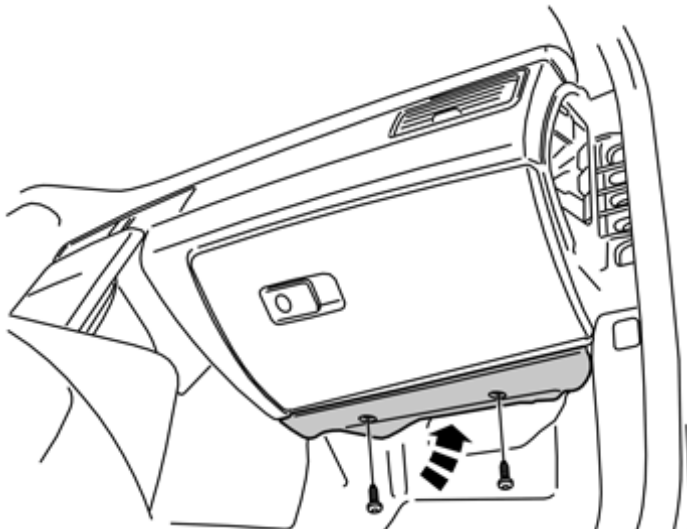

IMG-225272

**A**

Connect the prewired cable harnesses female connector to the courtesy lighting.

Connect the remaining connectors to each other.

**B**

Hide extra wire under the mat, install the panel, and tighten down.



# Installation instructions, accessories

Volvo Car Corporation Gothenburg, Sweden

56

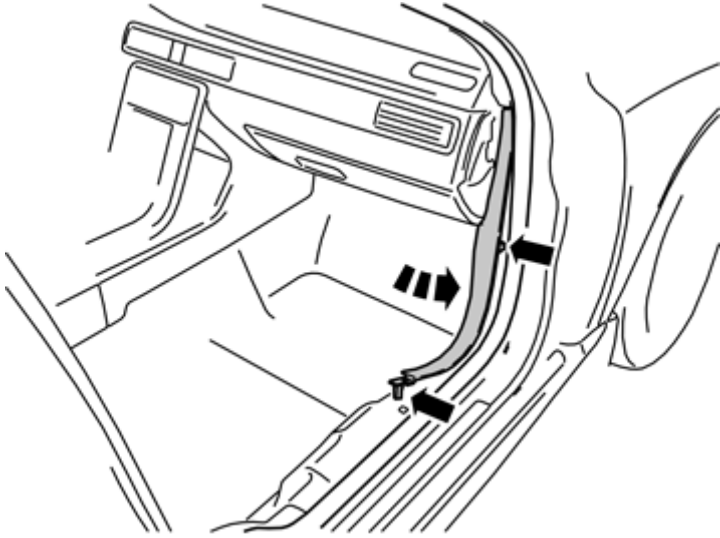

IMG-231438

57

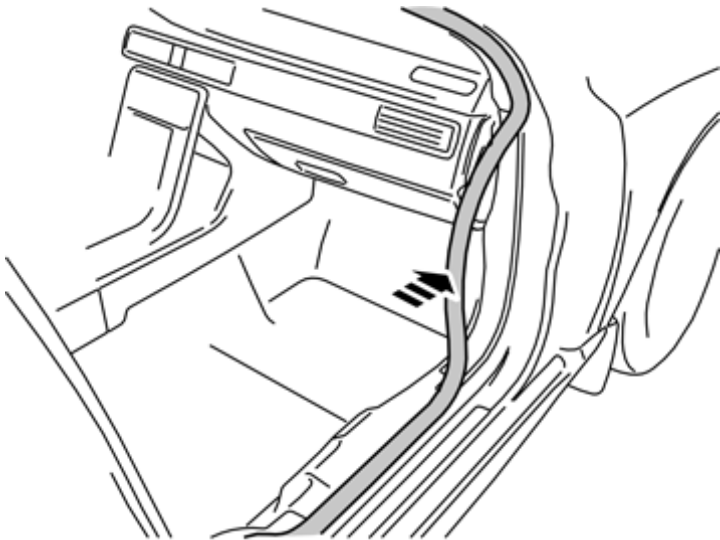

IMG-225281



# Installation instructions, accessories

Volvo Car Corporation Gothenburg, Sweden

58

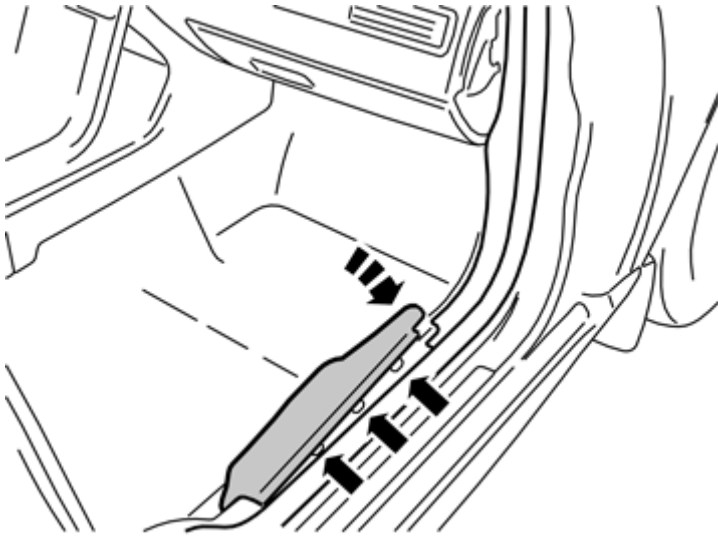

IMG-231437

59A

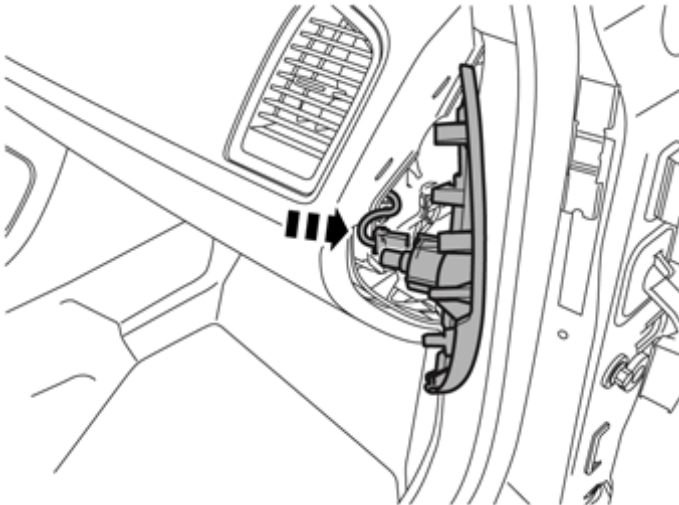

IMG-298526

A

**Note!**

Applies to cars with switch for passenger airbag.

59B

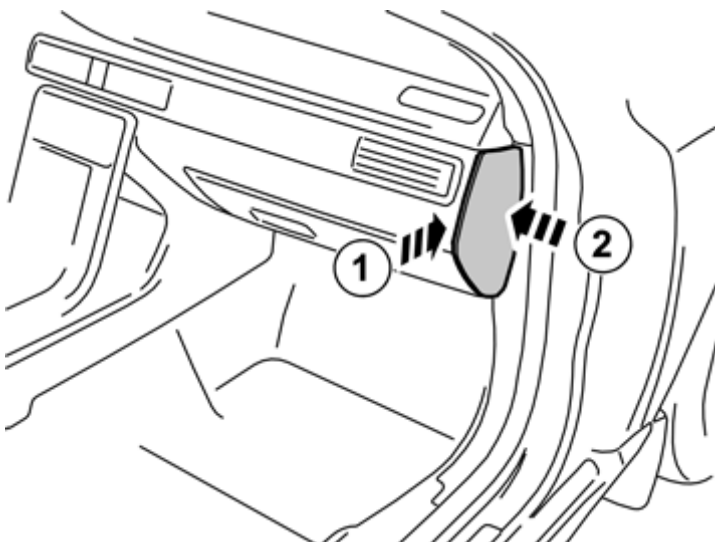

IMG-225282



# Installation instructions, accessories

Volvo Car Corporation Gothenburg, Sweden

60

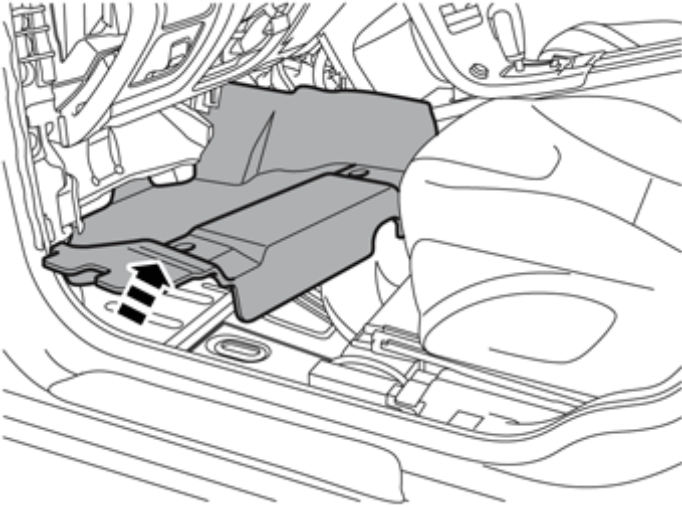

IMG-298583

61

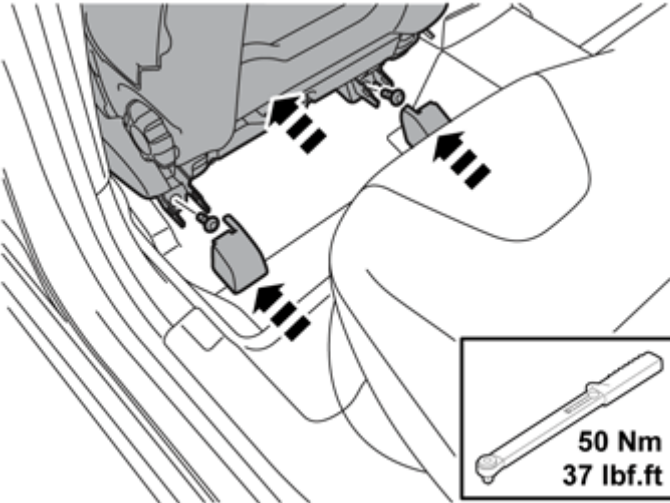

IMG-298584

62

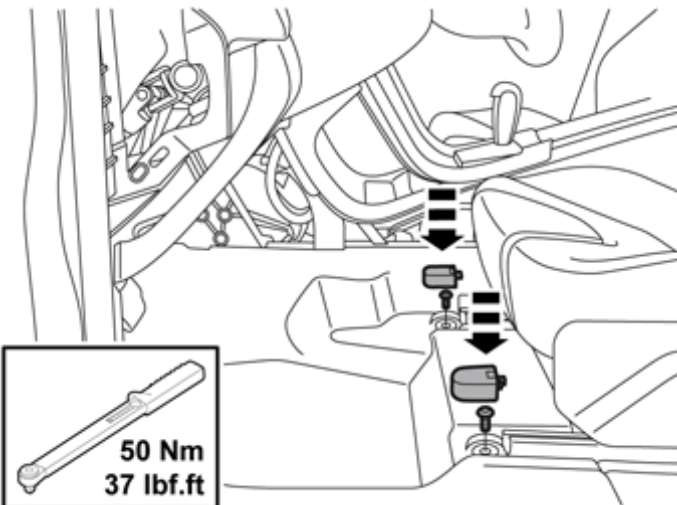

IMG-298586



# Installation instructions, accessories

Volvo Car Corporation Gothenburg, Sweden

63

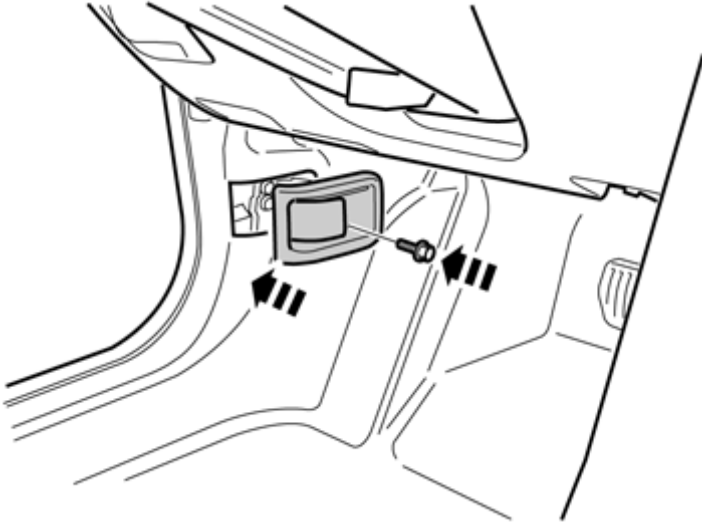

IMG-298587

64

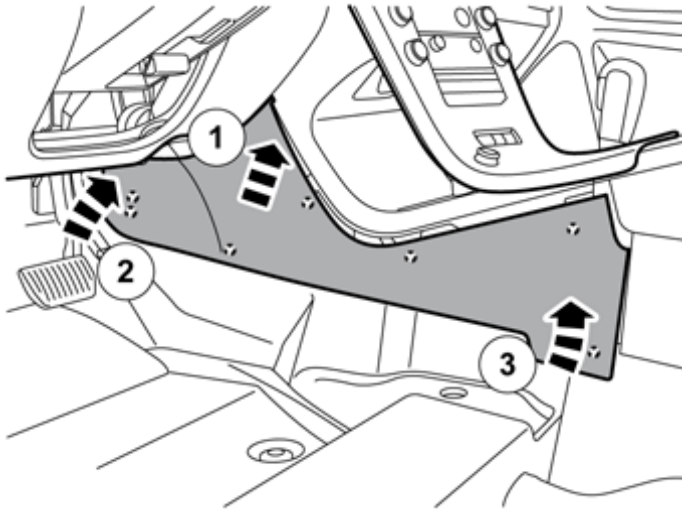

IMG-298588

65

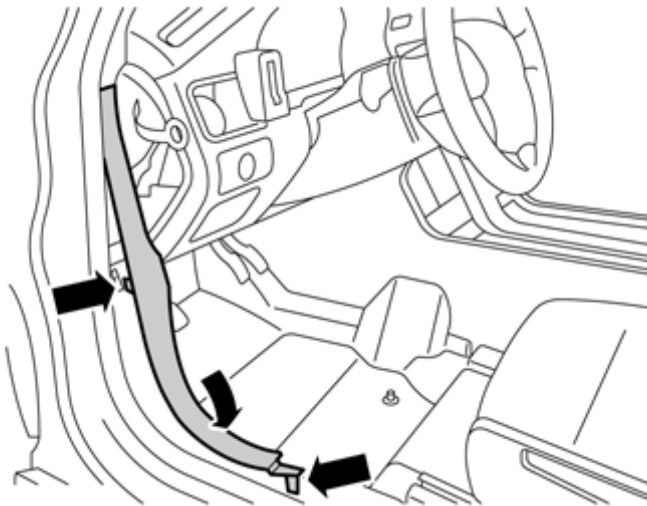

IMG-255785



# Installation instructions, accessories

Volvo Car Corporation Gothenburg, Sweden

66

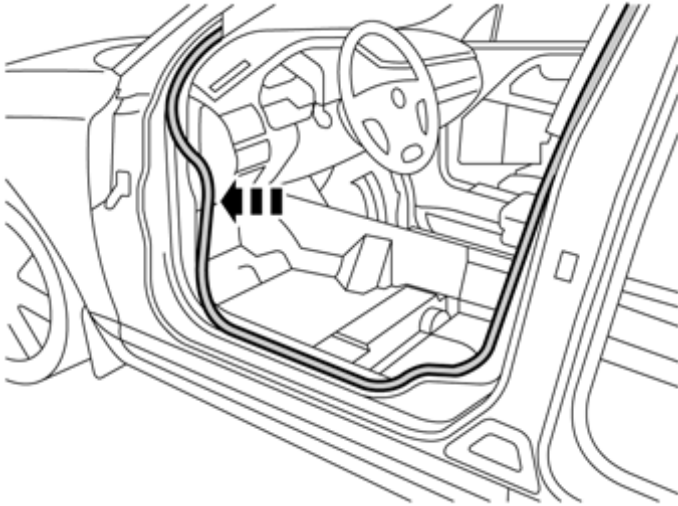

IMG-255786

67

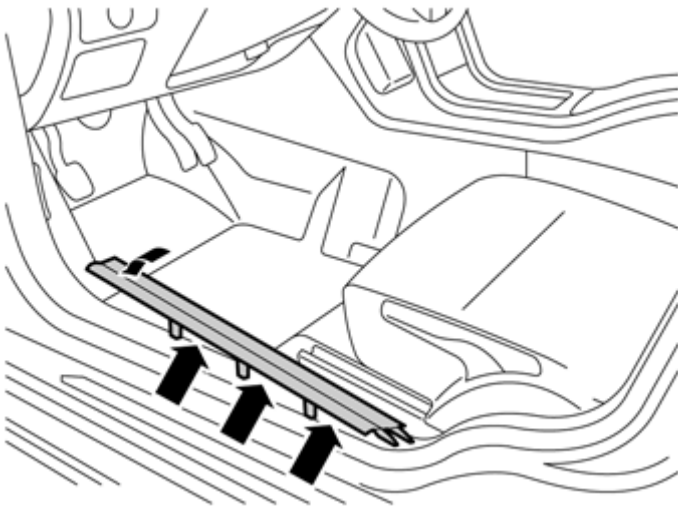

IMG-255787





# Installation instructions, accessories

Volvo Car Corporation Gothenburg, Sweden

68

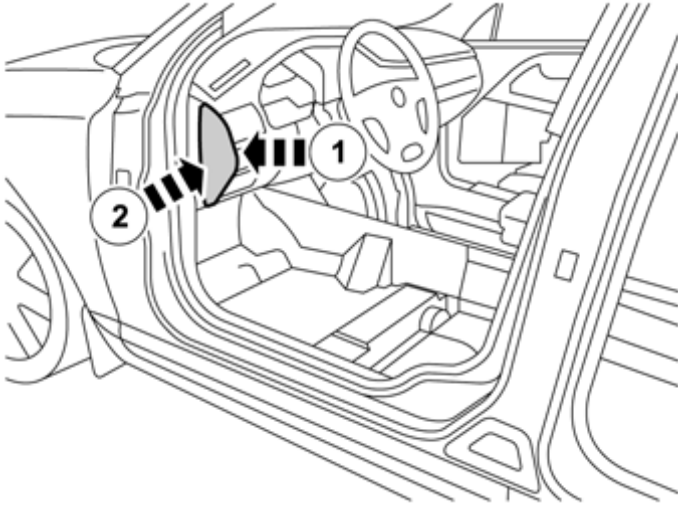

IMG-255788

69

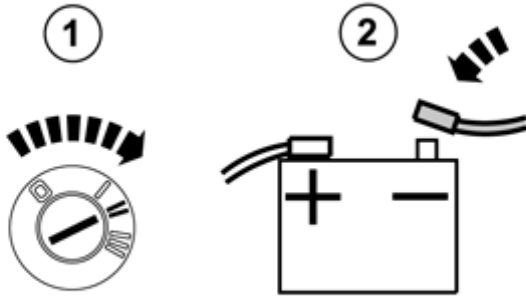

IMG-242267

## Sill mouldings rear doors



# Installation instructions, accessories

Volvo Car Corporation Gothenburg, Sweden

70

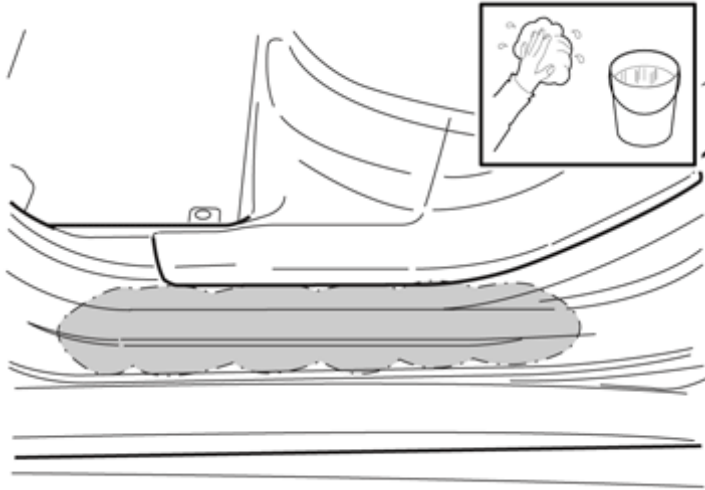

IMG-297874

## Sill mouldings rear doors

Wash the door sill

71

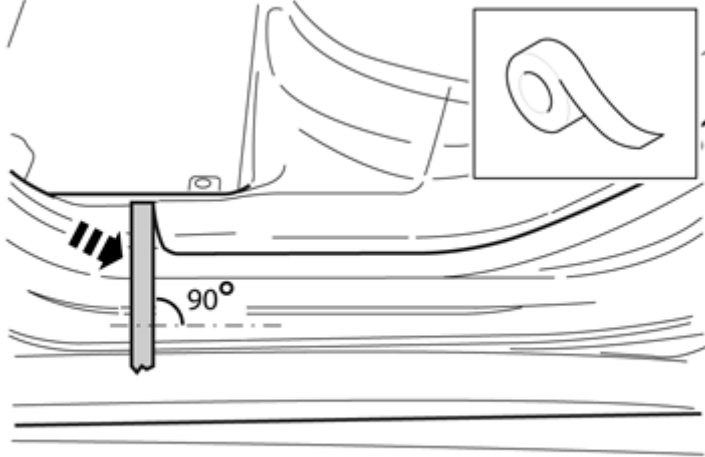

IMG-290349

Place a strip of tape in the front edge of the sill panel, and square to the edge of the door sill.

72

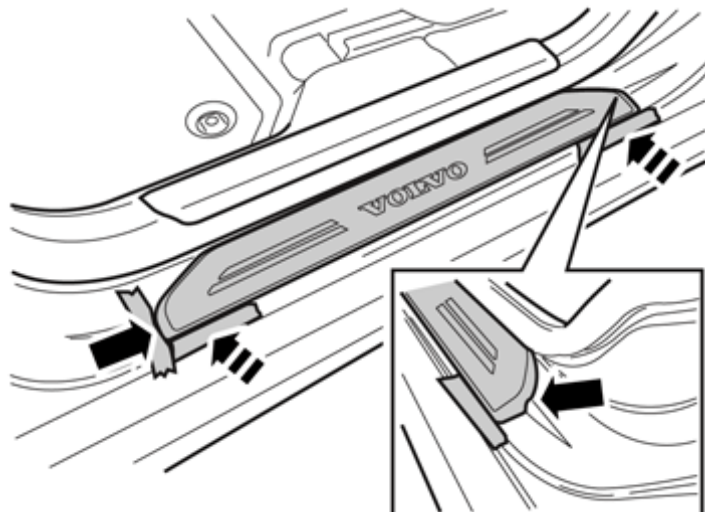

IMG-290343

Position the sill moulding by the strip of tape at the front edge and position it so that the cut-outs in both ends align with the corresponding door sill. Be careful when positioning so that the moulding is not misaligned.

Attach a strip of tape to mark the sideways position.





# Installation instructions, accessories

Volvo Car Corporation Gothenburg, Sweden

73

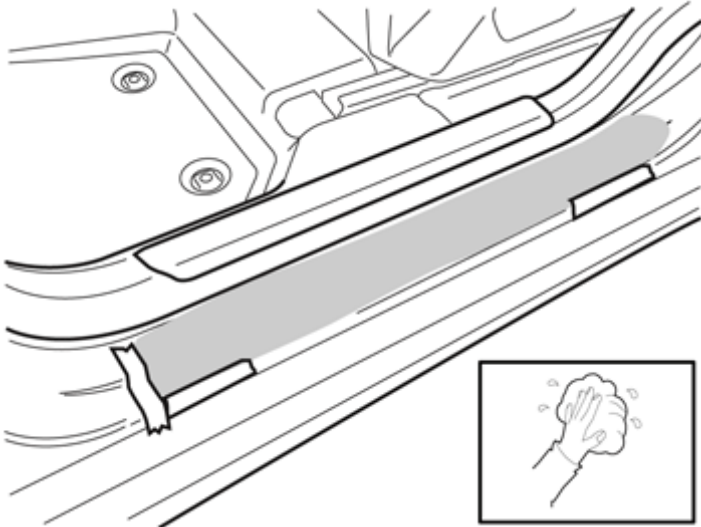

IMG-290344

Clean the marked surface on the sill using isopropanol and wipe dry.

74

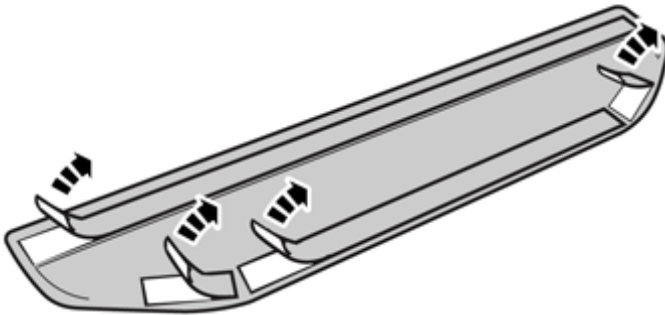

IMG-300145

Remove all the pieces of protective tape from the sill moulding.

75

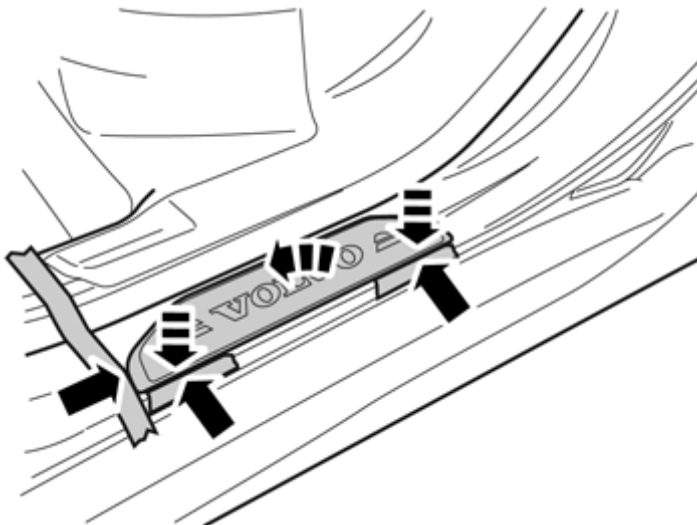

IMG-290403

Align the moulding with the tape markings and carefully fold it down against the sill and push into position. Watch out for the rubber moulding in the sill.

Remove the tape markings.



# Installation instructions, accessories

Volvo Car Corporation Gothenburg, Sweden

76

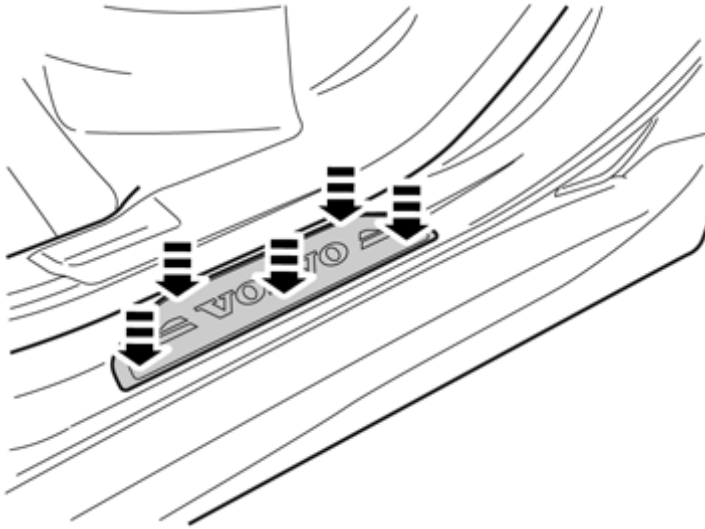

IMG-290404

Now press along the entire strip so that it fastens properly.

Press the moulding strip down firmly with a pressure of 2 kg/cm<sup>2</sup> along its entire length.

Repeat the operation on the other side.